

**Thermal-King Series, Bitterroot Double Reel, Models 50150
- up to 20' wide**

The blanket storage reel system assembly shall be portable, and consist of two side frames, side supports, two storage tubes, tube crank handle, transport casters and a braking system. It shall have a minimum storage capacity of 328-linear feet or 6,560 square feet of energy saving blankets.

Side Frames

The reel assembly shall have two (2) side frames. Each fabricated from square tubing 2.00" x 0.120" wall thickness, type 304 stainless steel polished to a 400 grit finish.

Side Supports

The side frames shall be connected by two- (2) 2" x 1" x 0.065" wall thickness square tube supports. Side supports shall be fabricated of type 304 stainless steel polished to a 400 grit finish.

Storage Tubes

The blanket storage reel system shall facilitate two (2) storage tubes. The tubes shall be fabricated of 4.50" x 0.120" wall, 304 stainless steel. The tubes shall be up to 20' long and shall be connected to each side frame by way of nickel-plated pillow block bearings. The blanket storage reel assembly shall be supplied with one 304 Stainless steel crank handle.

Casters

Stainless steel casters shall be provided with the blanket storage reel assembly. Six- (6) casters shall be provided. Each caster shall employ six- (6) inch diameter cast polyethylene wheels. The casters and wheels will be design to support a minimum of 1,600 pounds.

Brake Assembly

Two- (2) foot operated brake assemblies shall be provided with the blanket storage reel system. The brake shall be fabricated of 304 Stainless steel. Brake pads will be 2- (3.5) inch diameter made of non marring vulcanized rubber. The brake shall be supplied with a brake setting/release foot pedal.

Storage Reel and Blanket Cover

A storage reel blanket cover is an available option. The cover shall be fabricated of twelve by twelve woven polyethylene fabric that is to be double coated with an ultraviolet inhibiting film. The cover shall protect the blanket assemblies for premature wear and ultraviolet degradation.

Warranty

Two year limited warranty.

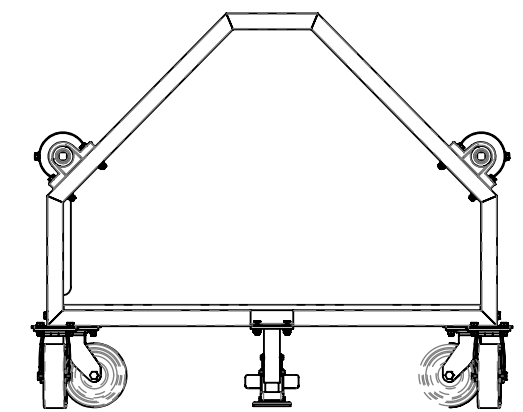
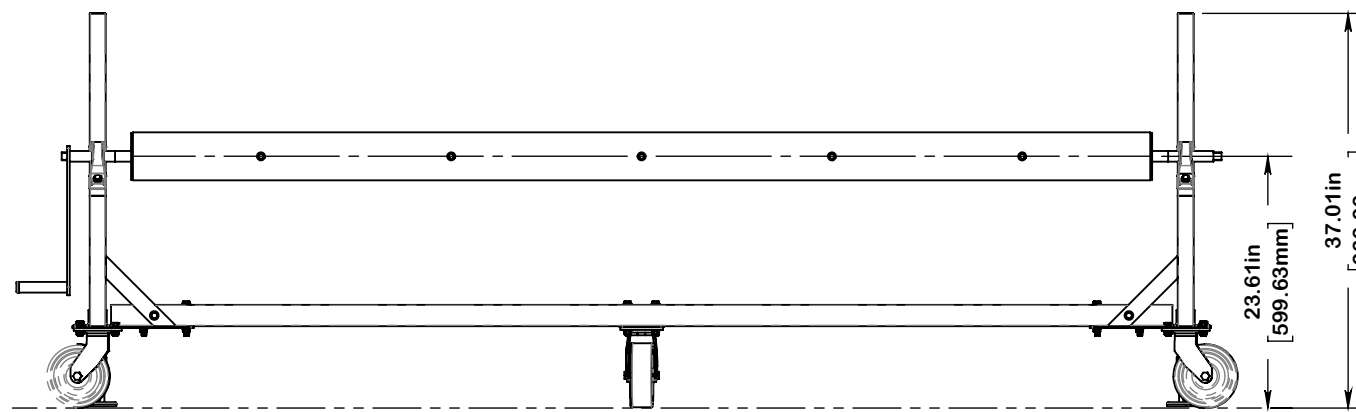
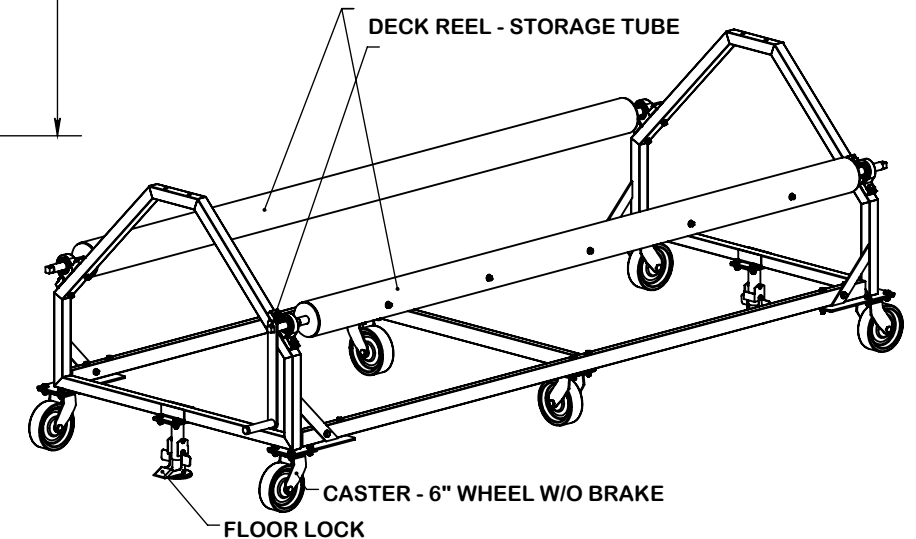
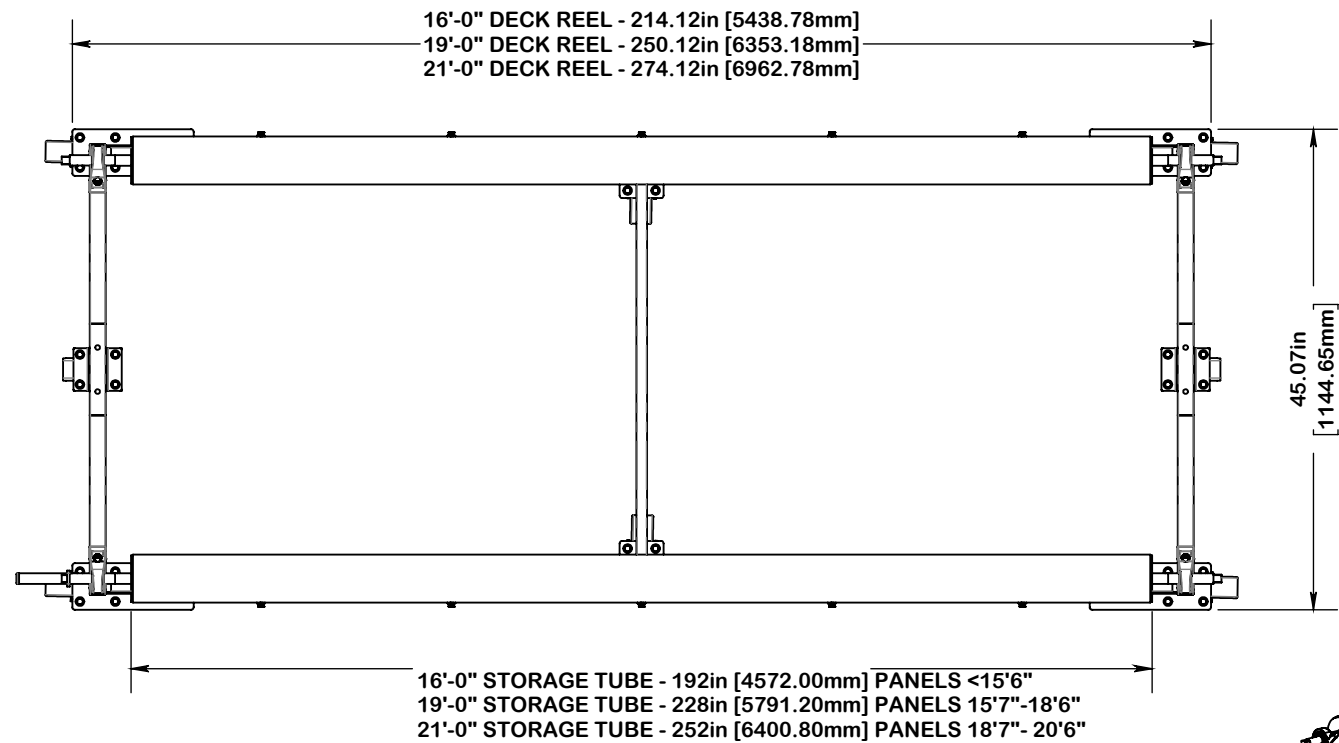

SPECTRUM
Aquatics

A PLAYCORE Company

7100 Spectrum Lane Missoula, Montana 59808
800.791.8056 www.spectrumaquatics.com

ENGINEERING DATA

PRODUCT:	DECK REEL - BITTERROOT II -			
MODEL #:	50150-00	CATALOG #:	50150-00	REVISION: A
MATERIAL:	304L STAINLESS STEEL			
FINISH #:	600 GRIT			

NOTE:

△ DIMENSIONS VARY WITH SPECIFIC APPLICATIONS. SPECIFICATIONS ARE NOMINAL AND ARE SUBJECT TO CHANGE. PLEASE CONTACT SPECTRUM AQUATICS FOR CUSTOM APPLICATIONS

◆ STORAGE CAPACITY OF 328 LINEAR FEET OR 5,560 SQR. FT. ◆ TOTAL WEIGHT CAPACITY OF 1,102 LBS. ◆ CAN BE UPGRADED TO A TRIPLE WINDER #50180 WITH A STORAGE CAPACITY OF 492 LINEAR FT. WITH A TOTAL WEIGHT CAPACITY OF 1,562 LBS.