

**ANCHORS AND ACCESSORIES**  
**MODEL - STEP TREAD 22"-15° 1.90" O.D.**

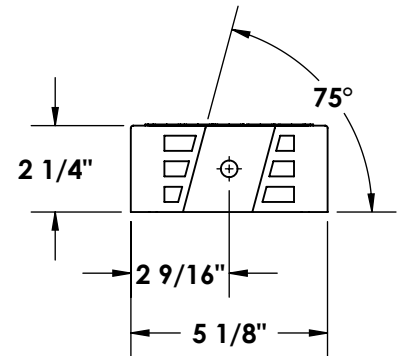

\*Note: Specifications are nominal and are subject to change.  
 Please contact Spectrum Products for custom applications.

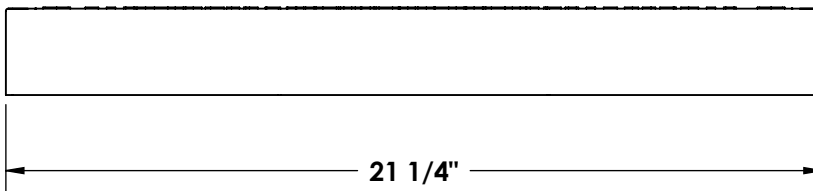
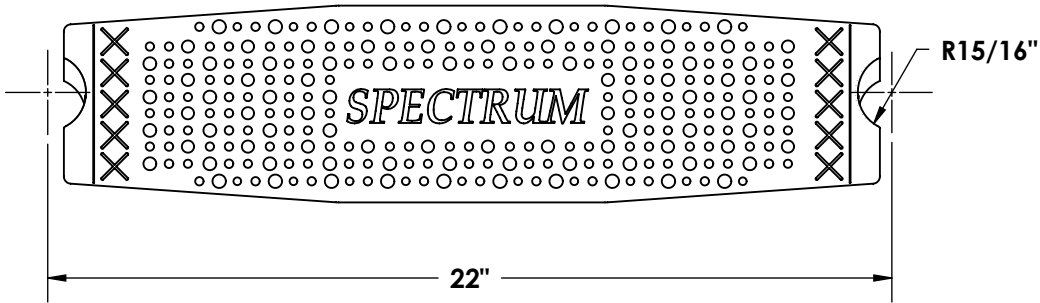
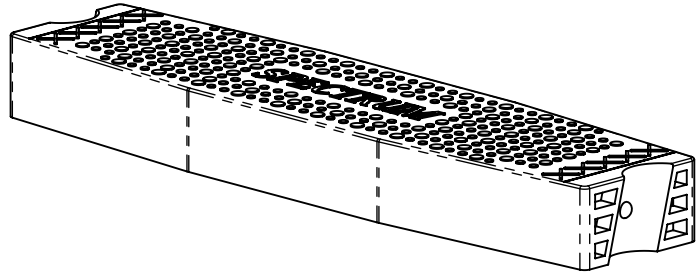

7100 Spectrum Lane  
 Missoula, Montana 59808  
 406.542.9781 \* 800.791.8056  
 Fax: 406.542.1158  
 www.spectrumproducts.com

**ENGINEERING DATA**

PRODUCT:	STEP TREAD 22"-15° 1.90" O.D.
PRODUCT #:	24414-00
REVISION:	A
MATERIAL:	PE HIGH DENSITY