

STARTING PLATFORMS

MAINTENANCE, CARE AND REPAIR FOR STARTING PLATFORMS AND FRAMES



SPECTRUM
AQUATICS
A PLAYCORE Company

7100 Spectrum Lane | Missoula MT 59808
www.spectrumproducts.com | info@spectrumproducts.com | 800.791.8056

DAILY TO WEEKLY MAINTENANCE

Cleaning your starting platforms on a regular basis is an essential part of ensuring longevity and minimizing rust formation. Regimented cleanings will also reduce stains and discoloration on the block surface. The frequency in which blocks should be cleaned depends upon how harsh the environment is in your pool facility. For instance, indoor pools with poor air circulation may require rinsing of starting platforms 1 - 2 times per week with tap water. This will ensure the removal of corrosive airborne contaminants that will inevitably land on the surface of your starting platforms.

Starting platforms should always be dried with a soft cloth, with attention given to the welded portions of the platform and any areas where bolts are used to join pieces of metal together. These areas are most susceptible to crevice corrosion. Starting platforms in outdoor facilities require similar levels of care, and we recommend that all starting platforms be covered when not in use to limit surface abrasions and discourage unwanted play.

General maintenance for 3M surfaces (top, wedge and step)

- 1 Rinse with fresh tap water (do not use high pressure power washer).
- 2 Use a plastic bristle scrub brush in a circular motion to gently remove stains.
- 3 Pat dry with a clean, soft cloth.

NOTE: When applicable, avoid scrubbing the edge sealant used to adhere the 3M grit to platform surface.

General maintenance for starting block frame

- 1 Rinse with fresh tap water.
- 2 Dry with a clean, soft cloth.

NOTE: Remember to rinse and dry the inside of the wedge and the underside of the platform top to prevent corrosion.

MONTHLY TO YEARLY MAINTENANCE

General maintenance for 3M surfaces (top, wedge and step)

- 1 Rinse with fresh tap water (do not use high pressure power washer).
- 2 Use a non-abrasive, non-chemical based cleaner (mild dish detergent), and a plastic bristle scrub brush with tap water to remove dirt and stains from the non-slip 3M surfaces. Use scrub brush in a circular motion so that you don't damage the non-slip surface.

NOTE: When applicable, avoid scrubbing the edge sealant used to adhere the 3M grit to platform surface.

General maintenance for stainless steel starting block frame

- 1 Use SpectraClean[®] and 3M scratch pad to remove any rust stains.

NOTE: Be sure to clean underneath the block top as well as inside the wedge.

- 2 Dry with a clean, soft cloth.
- 3 After thoroughly cleaning the stainless steel frame, apply SpectraShield[®] and let dry.
- 4 Add lubricant to spring pins and wedge/rail bracket to ensure smooth wedge movement and prolong the life of your springs. (See Xcellerator[®] 1/2" Spring Pin Replacement and Lubricant Application section below).

MONTHLY TO YEARLY MAINTENANCE

General maintenance for powder-coated frame

- 1 Use a non-abrasive soap and tap water. Avoid harsh chemicals and disinfectants. Always read the label instructions on any cleaner before applying it to the surface.
- 2 Check the structure for scratching or chips. If found, please follow “Spot/Scratch repair instructions,” found below.
- 3 If rust is present, clean the surface with a non-abrasive cleaner and contact us to purchase a powder-coat touch up kit.
- 4 After thoroughly cleaning the starting platform frame, you can apply car wax and buff to a shine to keep your platforms looking clean and new.
- 5 Add lubricant to the spring pins and wedge/rail bracket to ensure smooth wedge movement and prolong the life of your spring pins. (See Xcellerator[®] 1/2” Spring Pin Replacement and Lubricant Application section below).

Powder-coating disclaimer and repair suggestions

Powder-coating is a protective coating that improves product aesthetics and reduces corrosion by acting as a barrier against oxygen and water. Although powder-coating decelerates the onset of rust formation, it does not completely protect against it. Damage or chips to the powder-coating barrier can propagate, causing coating de-lamination. In order to keep your powder-coated starting platform in optimal condition it is necessary to examine the blocks on a regular basis for chips, scratches, or signs of corrosion around the bolts and welds. When addressed immediately, damage to powder-coating can be spot repaired to prolong product life.

SPOT/SCRATCH REPAIR INSTRUCTIONS

- 1 Remove any loose paint from the chipped area by scrubbing lightly with fine-grit sandpaper.



- 2 Wash the exposed surface and surrounding area with a mild detergent of SpectraClean[®] and a soft rag.

- 3 Rinse and dry the cleaned area thoroughly.

- 4 Immediately apply a zinc-rich, or other rust inhibiting, primer. Let dry.

- 5 Dip a small paint brush into your chosen paint color, and apply one coat of paint to the area. We recommend using a high-quality single stage 2k urethane automotive paint.



- 6 Immediately apply a zinc-rich, or other rust inhibiting, primer. Let dry.

- 7 Apply a third coat if necessary. Allow each coat to dry before applying another.

NOTES:

- A rust-inhibiting primer will help prevent damage from spreading and any exposed metal from rusting.
- This repair works well for minor chips and scratches, but will be noticeable on large patches
- It is difficult to match the exact color and thickness of the powder-coating. Do not expect a perfect match.
- Clear coat can be applied to the repainted area to match a glossy surface.

XCELLERATOR[®] 1/2" SPRING PIN REPLACEMENT

When properly cared for, spring pins will last up to three years. When spring pins break, it is usually due to particulate build up leading to a "sticky pin." When confronted with a sticky pin, swimmers may try to force the wedge to move causing the pin to break. In order to prevent this from happening, keep the wedge moving freely by lubricating the pins and rails.

Components and tools needed

- (2) spring pin assemblies for each Xcellerator[®] starting block
- (2) 1/2" Jam Nylock nuts
- (4) 1/2" flat washers

- 7/16" wrench for rear rail weldment acorn nut
- 5/8" wrench for interior spring assembly
- 3/4" wrench for exterior spring pin assembly nut
- 5/32" allen wrench for rear cover screws and rear weldment screws

Spring pin replacement steps

- 1 Remove the rear screws and acorn nuts from the left and right rail weldments using the 5/32" allen wrench and 7/16" wrench simultaneously. This will ensure that the wedge can be removed from the starting block.

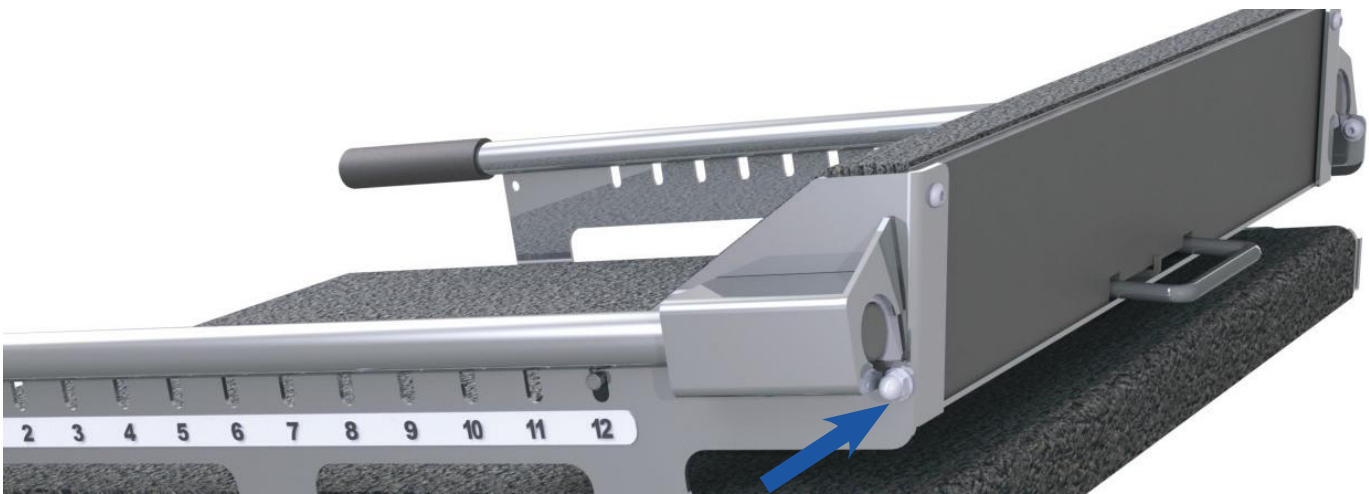

- 2 Remove the wedge from the starting platform.

XCELLERATOR[®] 1/2" SPRING PIN REPLACEMENT

- 3 Remove plastic backing from the rear of the wedge by removing the two screws using the 5/32" allen wrench.



- 4 Remove exterior nuts on the left/right sides of the wedge using the 3/4" wrench on the exterior nut and the 5/8" wrench on the exterior nut simultaneously.

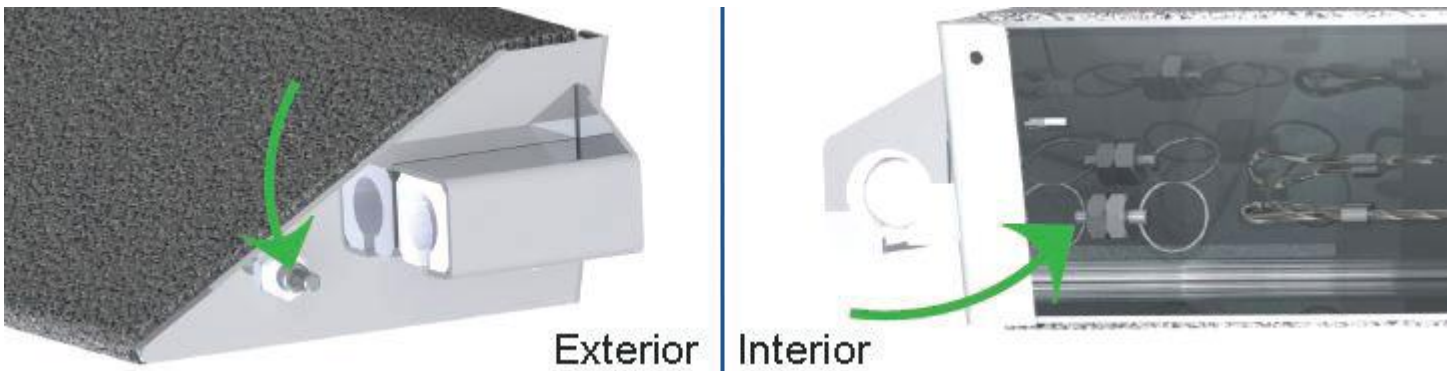

- 5 Remove each old spring pin assembly and then disconnect the two split rings from the wedge cable. Remove the old spring pin assemblies from the wedge.

- 6 Connect the new left and right spring pin assemblies to the wedge cable using the split key rings.

XCELLERATOR[®] 1/2" SPRING PIN REPLACEMENT

7 Locate the spring pins in the left and right exit holes of the wedge, leaving threading for exterior nuts

NOTE:

Placing washers on the interior of the track start wedge will help to fine tune how far the spring pin protrudes from the wedge when engaged. Ensure that the pin does not touch the grab rail weldments when retracted

8 Tighten exterior nuts down with the 3/4" wrench and interior nuts with the 5/8" wrench until the spring assembly is secure. Complete this step for both the left and right hand sides of the wedge.

9 Test the spring pins by pulling on the handle connected to the wedge cable.

10 Replace the plastic backing to the rear of the wedge. Then re-apply the rear screws to the wedge using the 5/32" allen wrench.

11 Place the wedge back on the starting platform, making sure that the spring pins slide freely during adjustment and engage with the grab rail weldments when the handle is released.

12 Replace the rear screw and acorn nuts on the left and right rail weldments to secure the wedge to the starting platform.

13 Repeat this process for all required Xcellerator[®] Starting Platforms.

XCELLERATOR[®] START WEDGE MAINTENANCE

Lubricant placement (once a month, or as needed)

(on both sides)

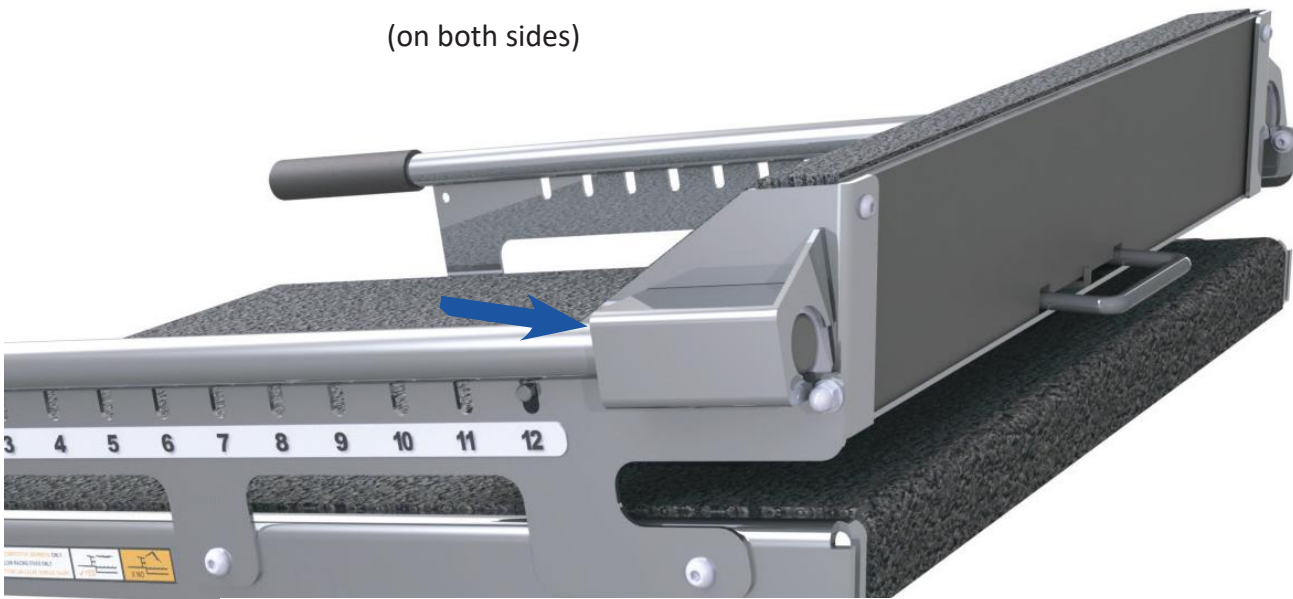

(on both sides)

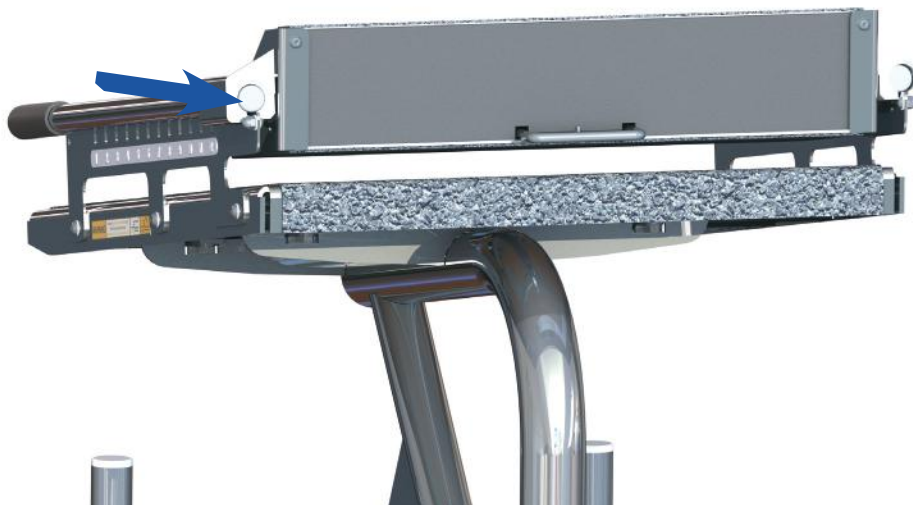

START WEDGE GENERAL MAINTENANCE

- 1** Inspect current spring pins on track start wedge for corrosion, damage, and proper engagement with the side rails when extended. Ensure that the spring pins do not make contact with the side rail weldments during wedge adjustment and that the spring pins locate properly when adjustment handle is released.
- 2** If pins require replacement, ensure that the correct replacement parts are used. This can be verified by measuring the threaded portion of the spring pin body (either 1/2" or 3/8" diameter). Consult the spring pin replacement instructions for further details on replacement.
- 3** Inspect and test the spring pins monthly. Apply food grade silicone to the pin and rotate/pull on the pin several times to allow the lubricant to work its way into the body of the part to maintain proper action of pins.
- 4** Apply WD-40 to the side rails with the exception of the front 6 inches that the swimmer utilizes during a start. This ensures smooth motion of the track start wedge along the rails during adjustment.
- 5** Encourage swimmers to use the track start wedge properly. Make sure that the pins are extended and located in a slot before initiating a start. Performing a start without proper pin location will result in damage or failure of the pins.