

### 8' Tagline Stanchion Post

The stanchion post shall be fabricated of 1.90" x .145" 316L Stainless Steel Round Tube. It shall be 96" in overall length and have a ring on its top surface and a cleat for winding line. The stanchion post shall have bent two support legs attached to its lower end.

#### Anchor

The stanchion post shall be supported by a 1.90" x 6" Tagline Anchor Assembly, P/N 1810360. This item is sold separately.

#### Cleat

The stanchion post will be equipped with one (1) stainless steel cleat. The cleat shall be fabricated from .375" stainless steel round bar. The cleat shall be welded to the main post of the tagline stanchion.

#### Warranty

Spectrum standard warranty.

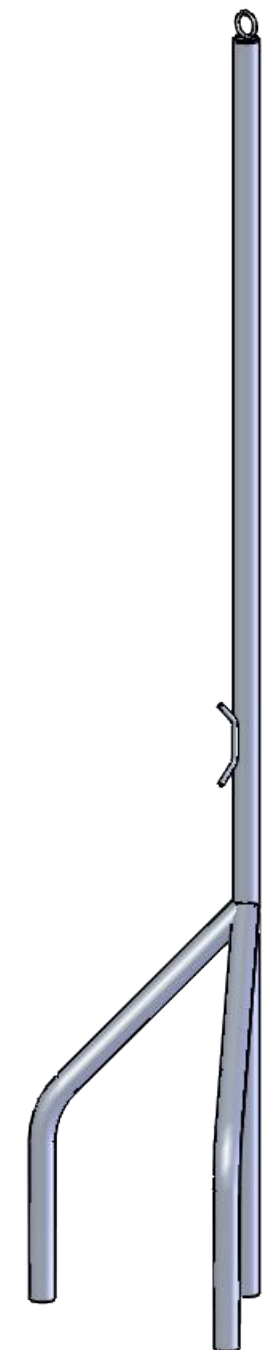
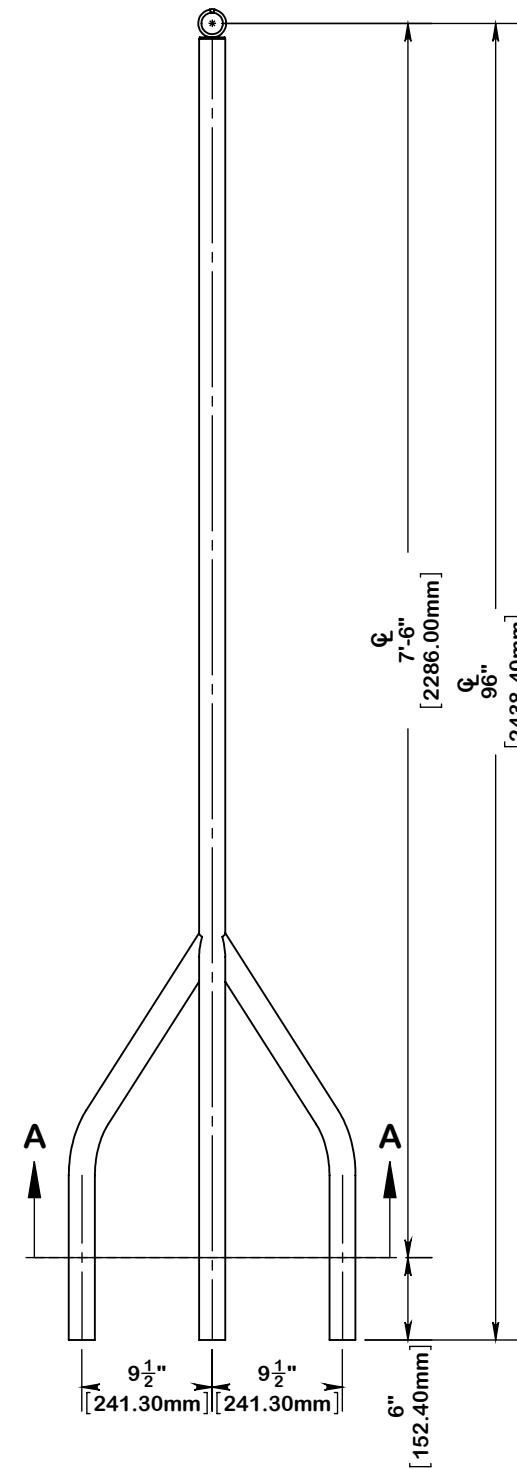
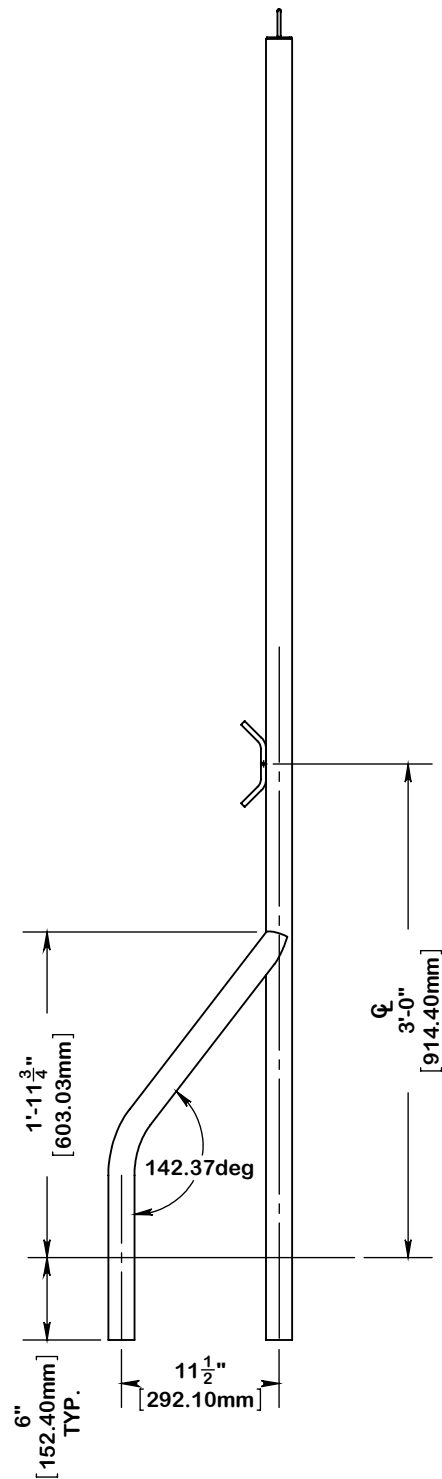
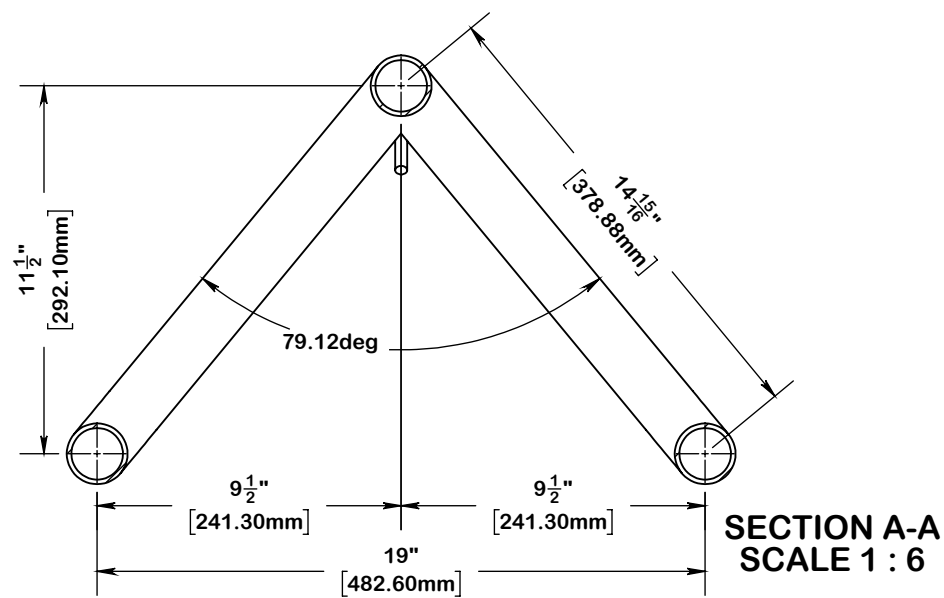

A PLAYCORE Company

7100 Spectrum Lane Missoula, Montana 59808  
800.791.8056 www.spectrumaquatics.com

## ENGINEERING DATA

PRODUCT:	TAGLINE STANCHION 8'-0" 316L - WITH CLEAT			
MODEL #:	2010607	CATALOG #:	2010607	REVISION: A
MATERIAL:	1.90"x.145" 316L SERIES S.S. TUBE			
FINISH #:	PASSIVATE IAW ASTM A967			

#### NOTE:

*△ DIMENSIONS VARY WITH SPECIFIC APPLICATIONS. SPECIFICATIONS ARE NOMINAL AND ARE SUBJECT TO CHANGE. PLEASE CONTACT SPECTRUM AQUATICS FOR CUSTOM APPLICATIONS*